



Applications

- Raw water turbidity
- Flocculation monitoring and flocculant metering
- Filtration monitoring and control
- Filter backflushing
- Monitoring of reservoirs and supply to networks

In water treatment processes for drinking water and for industrial applications

Features

- Contactless: measurement in a free-falling water stream
- Complies with standard EN ISO 7027
- Measuring span 0 ... 4000 FNU
- Automatic adjustment using an internal solid reference (optional)
- Version "P" for measurement under pressure

ON-LINE TURBIDIMETER AQUASCAT

ON-LINE TURBIDIMETER AQUASCAT

Turbidity measurement for process control

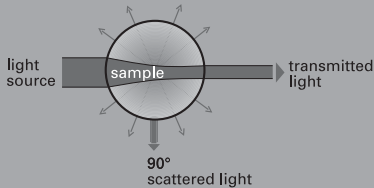

Scattered light measure- ment in a free-falling water stream

Versions



Calibration and adjustment

Turbidity is created in liquids by solid particles. When a light beam is passed through the sample, these particles scatter it. Measurement of the scattered light intensity and determination of the turbidity level therefore provide reliable information about the concentration of the solid particles in the liquid.

Turbidity is an important measured variable for ensuring water purity, particularly in drinking water treatment and for controlling individual process steps such as filtration and flocculation.

For many years SIGRIST has been producing instruments for measuring turbidity in a free-falling water stream. This contactless measurement eliminates all problems of window fouling as a result of solids or chemical deposits. The need for servicing is minimized as a result. And because stray light is reduced significantly, it becomes possible to measure extremely low turbidity levels precisely – even below 0.01 FNU. AquaScat makes it possible to measure 90° scattered light to ISO 7027 in a free-falling stream.

Three different AquaScat versions are available to meet the needs of various applications:

AquaScat WTM, with free-fall measurement and a resolution of 0.001 FNU, is predestined especially for use in clean water. Its measurement span is 4000 FNU.

AquaScat HT is a low-cost version with free-fall measurement, a measuring span of 4000 FNU and a resolution of 0.1 FNU. It is intended mainly for applications in raw water.

AquaScat P is a closed-flow-cell version for measuring highly gaseous water under pressure. It has a measuring span of 100 FNU and a resolution of 0.001 FNU.

The AquaScat is calibrated at the factory with Formazine in FNU units. Thanks to the dual-beam measurement method, this calibration is very stable. For calibration checking to ISO 9001, a calibrating unit with a solid reference is available that eliminates the need to handle Formazine. For the AquaScat WTM version, integral automatic calibration to a solid reference is available optionally. Even less servicing is required with this option.

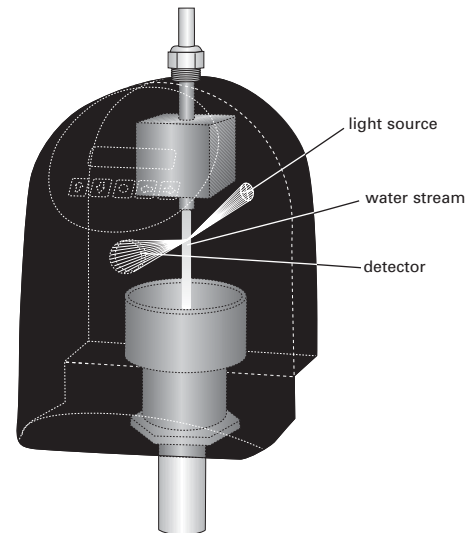

Operation and communication

AquaScat is operated with an integral keypad. The two-line LC display and a menu structure with plain text guidance provide easy access for operation, configuration and servicing. The AquaScat has two 0/4..20 mA current outputs and two independently configurable relay contacts for limit and alarm functions.

A PROFIBUS DP interface is offered optionally. The digital interface enables direct transmission of measured data as well as instrument control.

Installation / mounting

AquaScat is mounted vertically on a wall or bracket as close as possible to the sampletaking point. Hoses are employed for sample supply and return. A control valve must be provided for adjusting sample flow between 2.5 l/min and 7 l/min (AquaScat WTM/HT) or between 0.2 l/min and 2 l/min (AquaScat P).

Dimensions

AquaScat WTM/HT

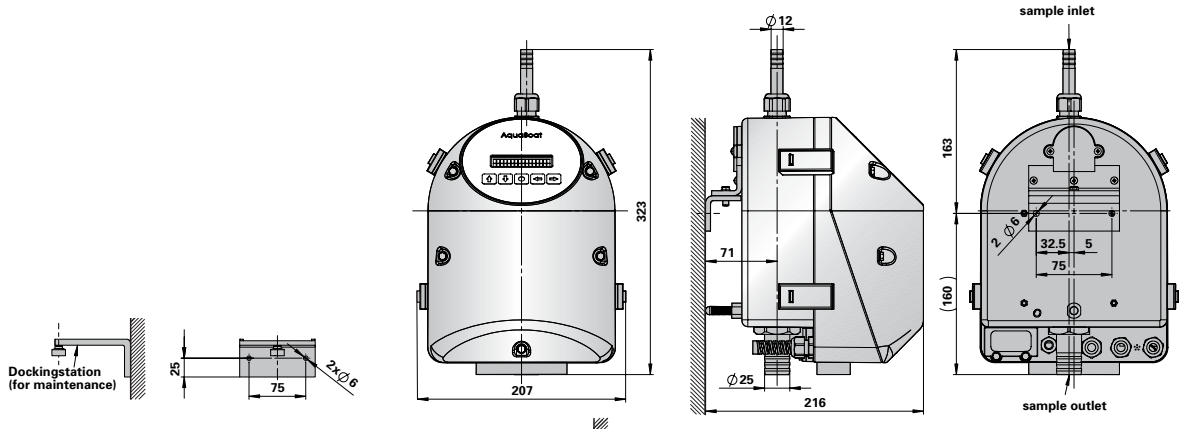

AquaScat P

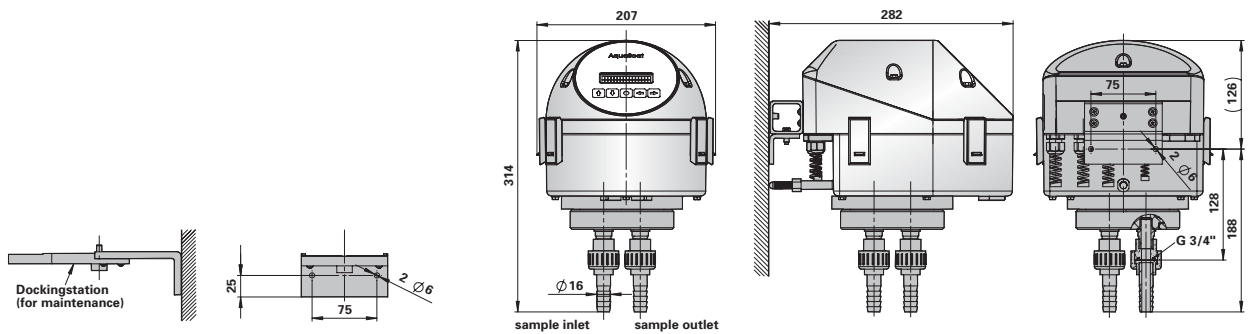

Wiring diagram

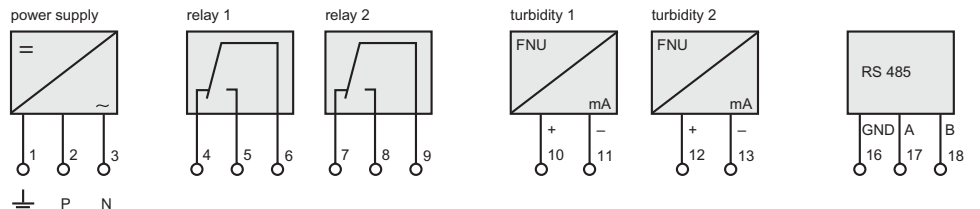

SPECIFICATIONS

Turbidity measurement

Measuring principle:	90° scattered light measurement
Measuring span:	0 ... 4000 FNU (WTM/HT); 0 ... 100 FNU (P)
Measuring ranges:	8 freely configurable ranges
Standard setting:	WTM: 0..0.1 / 0..0.3 / 0..1 / 0..3 / 0..10 / 0..30 / 0..100 / 0..500 FNU HT: 0..10 / 0..30 / 0..100 / 0..200 / 0..500 / 0..1000 / 0..2000 / 0..4000 FNU P: 0..0.1 / 0..0.3 / 0..1 / 0..3 / 0..10 / 0..30 / 0..50 / 0..100 FNU
Resolution:	0.001 FNU (WTM/P) 0.1 FNU (HT)
Measurement wavelength:	880 nm

Flow cell WTM/HT

Installation:	measurement on-line; outlet pressureless
Sample supply/return:	hoses, inside diameter 12 mm / 25 mm
Sample flow:	2.5 ... 7 l/min
Inlet/outlet material:	stainless steel 1.4435 (316L) / PVC
Sample temperature:	0 °C ... +40 °C
Ambient temperature:	0 °C ... +50 °C

Flow cell P

Sample supply/return:	hoses, ID 16 mm or GF system
Sample flow:	0.2 ... 2 l/min
Material:	POM / PVC
Pressure:	6 bar
Sample temperature:	0 °C ... +40 °C
Ambient temperature:	0 °C ... +50 °C

AquaScat Photometer

Electronics degree of protection:	IP 54
Weight:	3.2 kg (WTM/HT) 3.6 kg (P)
Power supply:	85 ... 264 V / 47 ... 63 Hz or 24 V DC
Power input:	11 W
Display:	LC display with plain-text information
Current outputs:	2 x 0/4...20 mA; max. burden 600 W; with electrical isolation, max. 50 V against earth
Limits:	2 separately configurable relay contacts 250 V AC, 4 A
Digital interface:	Profibus DP (optional)

Represented by:

 **SIGRIST**
PROCESS-PHOTOMETER

SIGRIST-PHOTOMETER AG • Hofurlistrasse 1 • CH-6373 Ennetbürgen
Phone +41 (0) 41/624 54 54 • Fax +41 (0) 41/624 54 55
www.photometer.com • e-mail info@photometer.com

